



REPAIRS FAULT FINDER

FOR TENANTS

Please take time to read through this fault finder guide to accurately establish any faults within your property. You can report any faults to us by emailing or calling us on the numbers below with your full property address and outlining any faults.



Contents

- 1** Baths and Showers
Doors External
- 2** Doors - Dry Riser
Doors - Fittings
- 3** Doors - Garage
Doors - Internal
- 4** Doors - Locks
Drainage
- 5** Electrics
Externals
- 6** Floors, Walls & Ceilings
Glazing
- 7** Gutters
Heating & Hot Water
- 8** Kitchen Units
Roofs
- 9** Sinks and Basins
Stairs
- 10** Toilets
Water Services
- 11** Windows - Wooden
Windows - Metal
- 12** Windows - IPVC/Alumin

Baths and showers

What is the fault and its number?

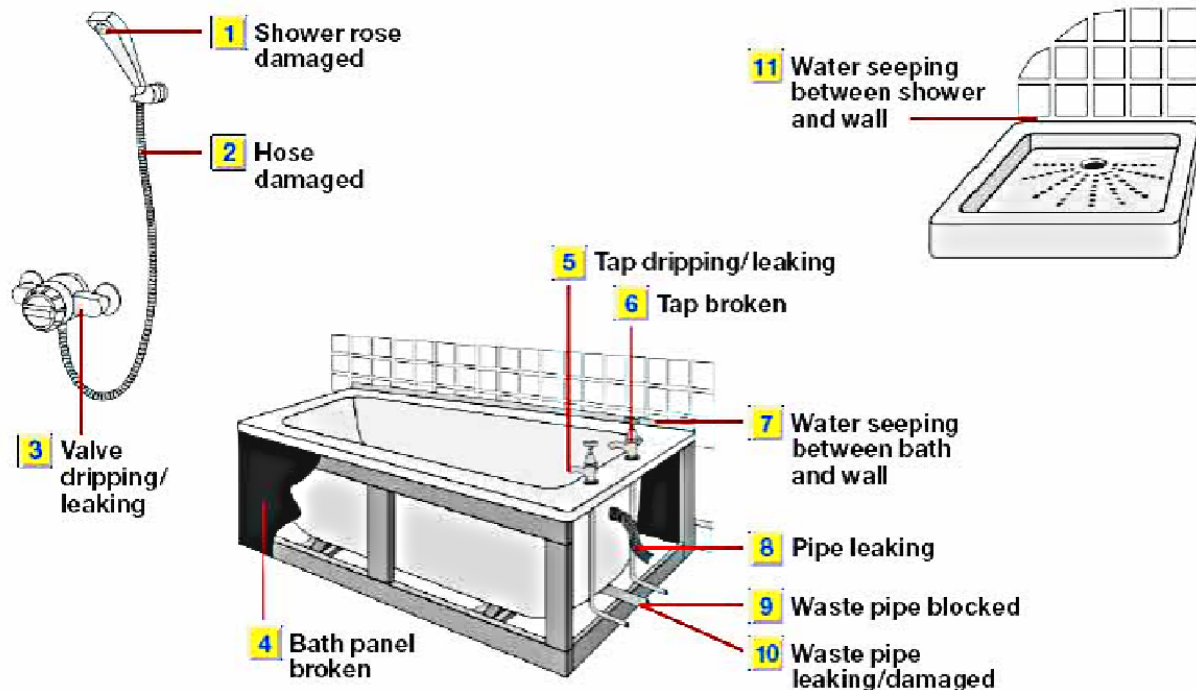

Doors - external

What is the fault and its number?

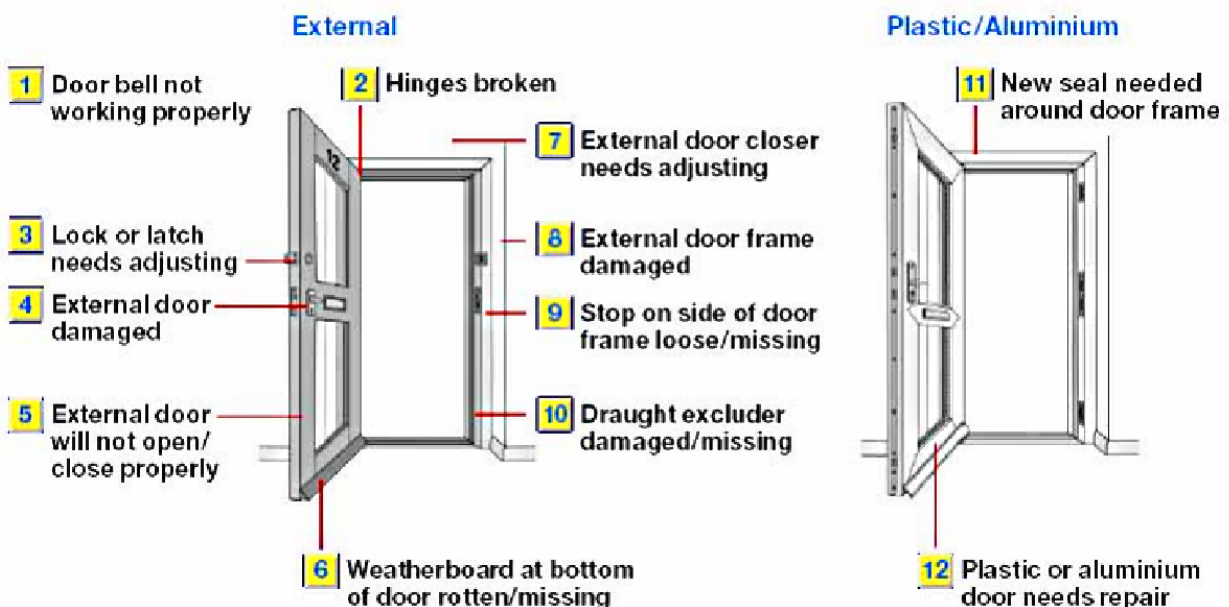

Doors - dry riser

What is the fault and its number?

6 Loft access needs repair

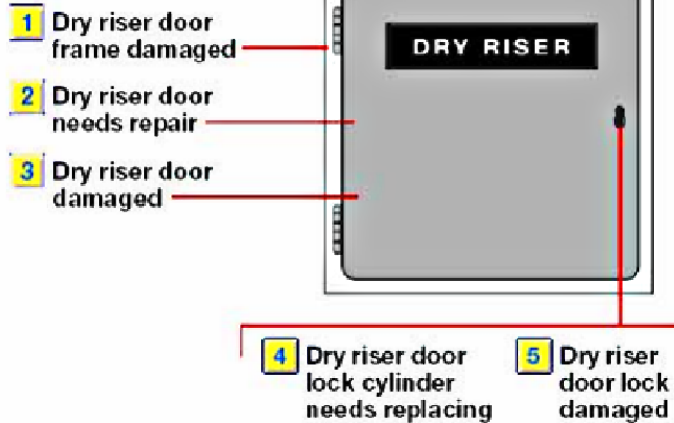

Doors - fittings

What is the fault and its number?

1 Door handle broken



2 Internal door lock/latch broken



3 Closer on side of door broken

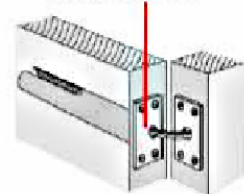

4 Cupboard hinge broken



5 Door hinge broken



6 Drawer handle broken

7 Cupboard handle broken

9 Security chain broken

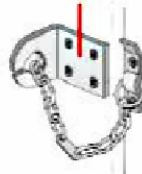

8 Door viewer broken

10 Postal flap broken



Doors - garages

What is the fault and its number?

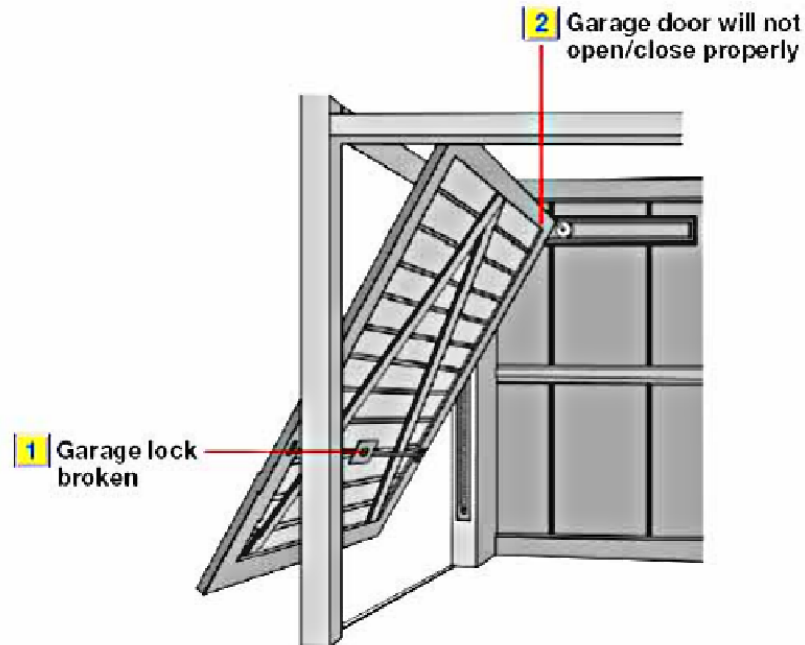

Doors - internal

What is the fault and its number?

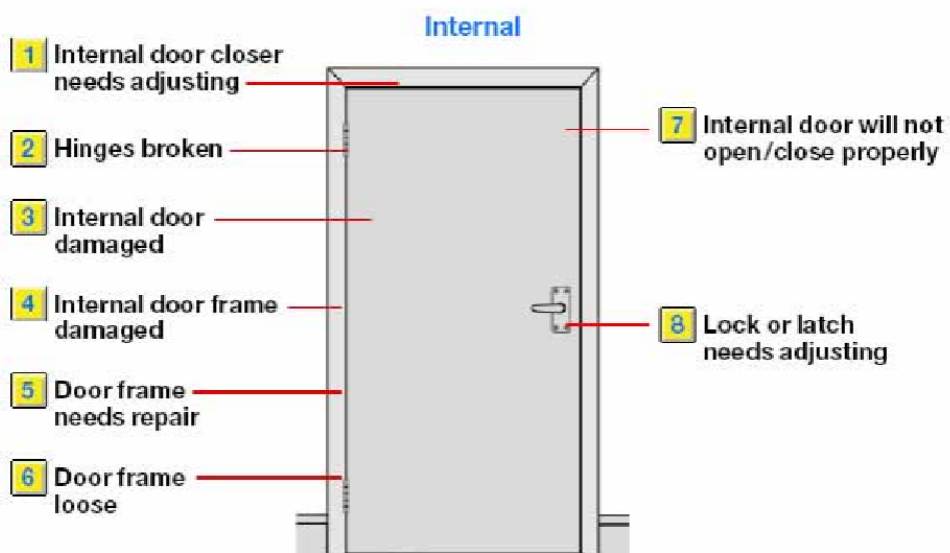

Doors - locks

What is the fault and its number?

- 1 New cylinder needed for night latch (Yale type)

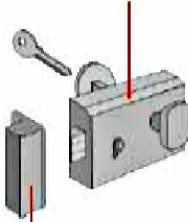

- 2 Mortice lock broken

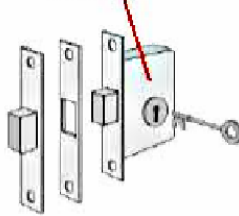

- 3 New cylinder needed for multi secure door

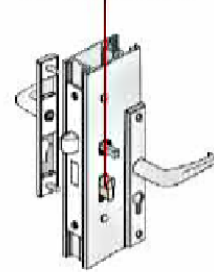

- 4 Night latch (Yale type) broken

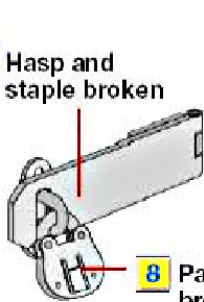

- 6 Padbolt broken

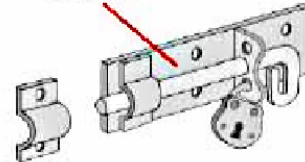

- 7 Bolt broken

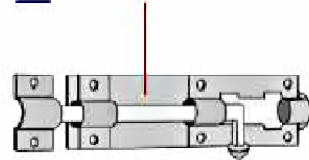

- 5 Hasp and staple broken

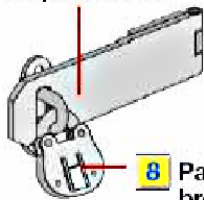

- 8 Padlock broken



Drainage

What is the fault and its number?

- 1 Stack leaking/damaged

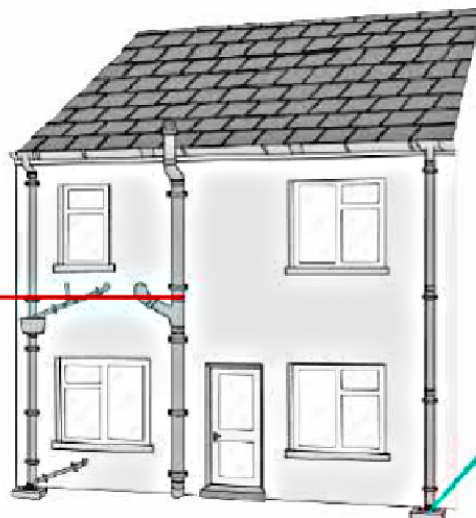

- 2 Gully grating broken/missing

- 3 Concrete/brickwork around gully damaged

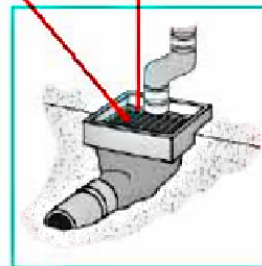

- 4 Drain cover and frame need repair

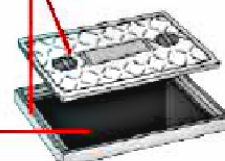

- 5 Drain blocked

Electrics

What is the fault and its number?

- 1 Fluorescent fitting damaged

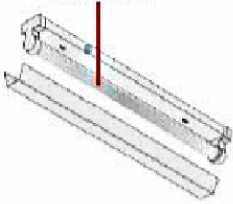

- 2 Wall switch not working properly

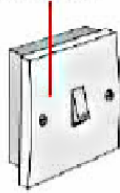

- 3 Socket not working properly



- 4 Door bell not working properly



- 5 Spur outlet not working properly

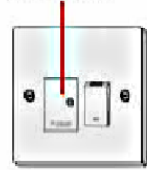

- 6 Cooker control not working properly

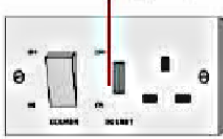

- 7 Electric extractor fan (not WC or utility room) not working properly



- 9 Immersion heater not working properly

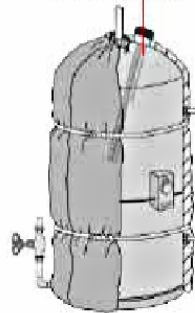

- 10 Storage heater not working properly

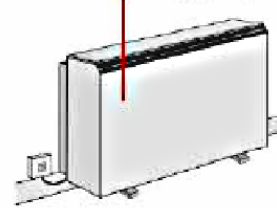

- 8 Electric extractor fan in WC or utility room not working properly

Externals

What is the fault and its number?

- 1 Chain link fence or post damaged

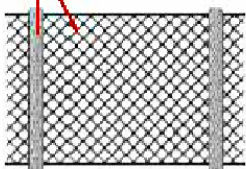

- 2 Timber fence or post damaged

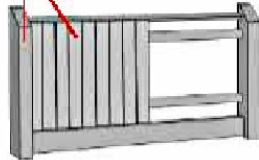

- 4 Asphalt path damaged

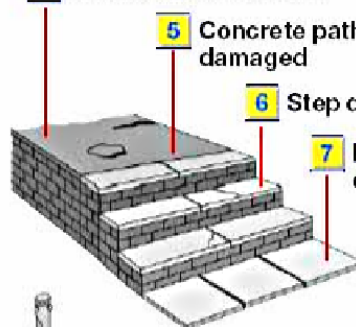

- 5 Concrete path damaged

- 6 Step damaged

- 7 Paving slabs damaged

- 3 Dust chute hopper or frame loose



- 8 Timber gate will not open/close properly

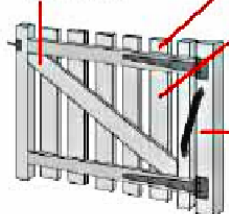

- 9 Timber gate needs rehangng

- 10 Timber gate damaged/missing

- 11 Gate post damaged/missing

- 12 Metal gate damaged/missing



- 13 Metal locking post damaged



- 14 Metal railing loose/damaged

- 15 Metal balustrade loose/damaged

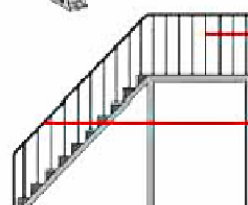

Floor, walls and ceilings

What is the fault and its number?

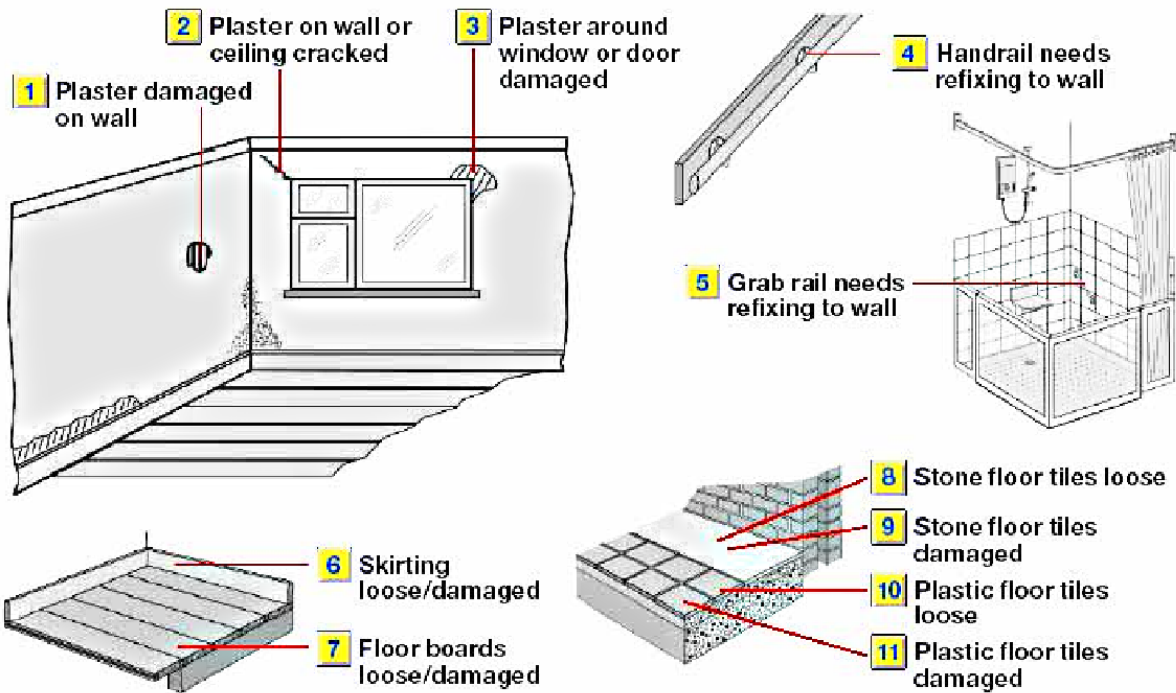

Glazing

What is the fault and its number?

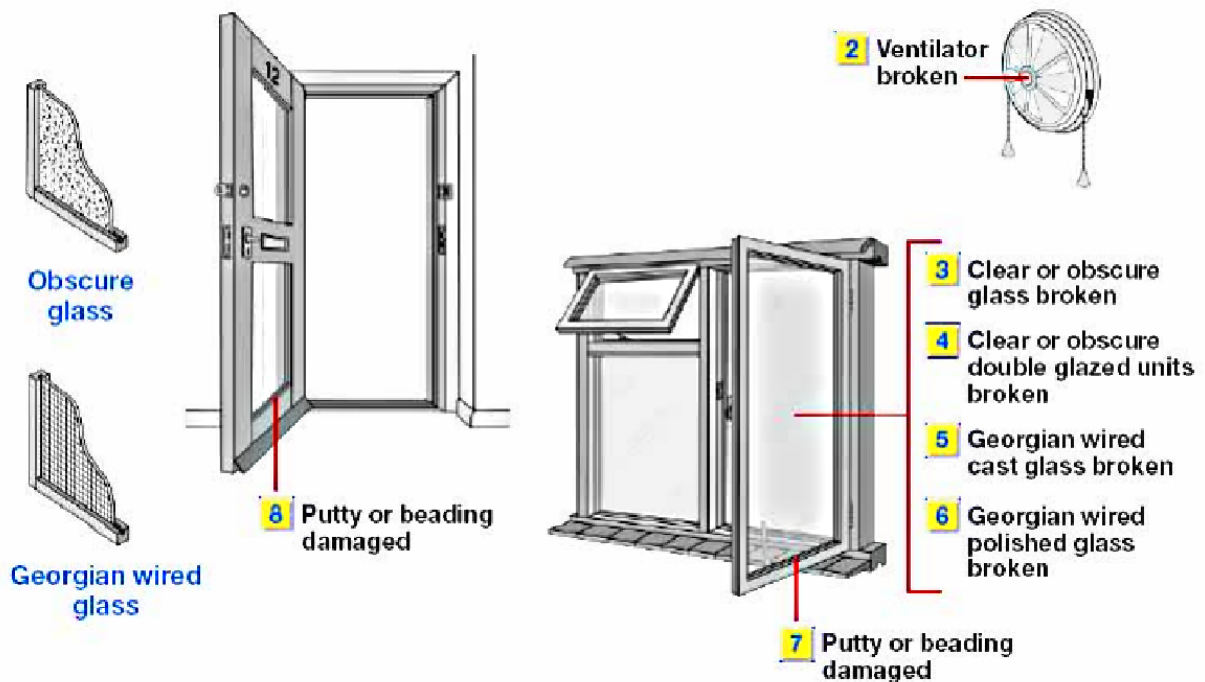

Gutters

What is the fault and its number?

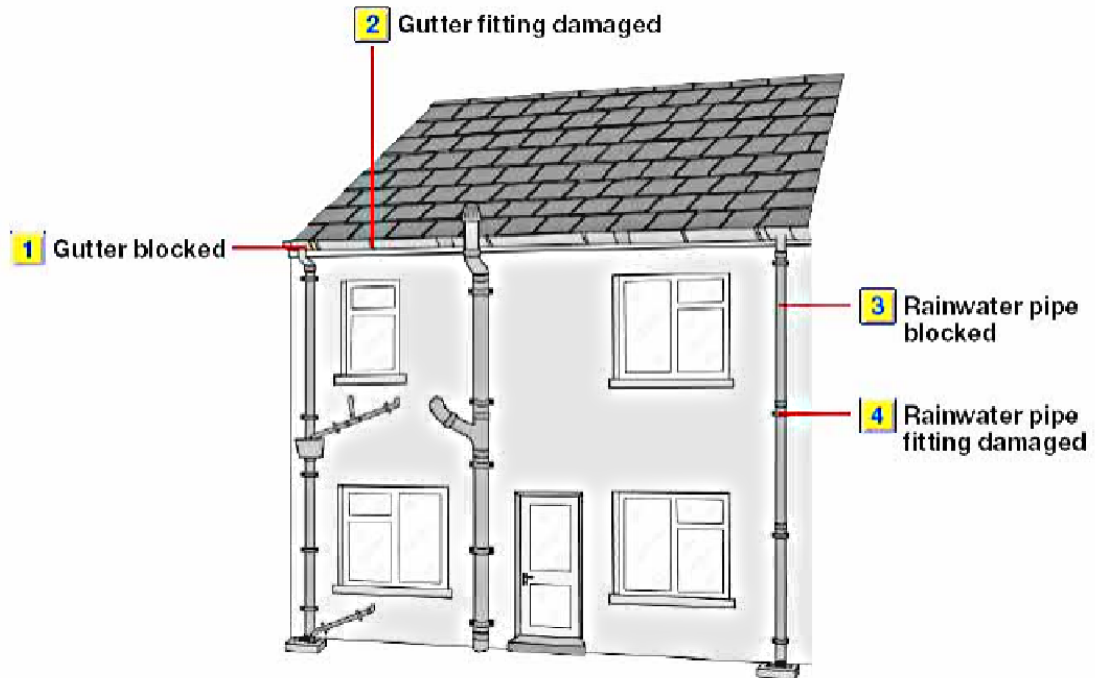

Heating and hot water

What is the fault and its number?

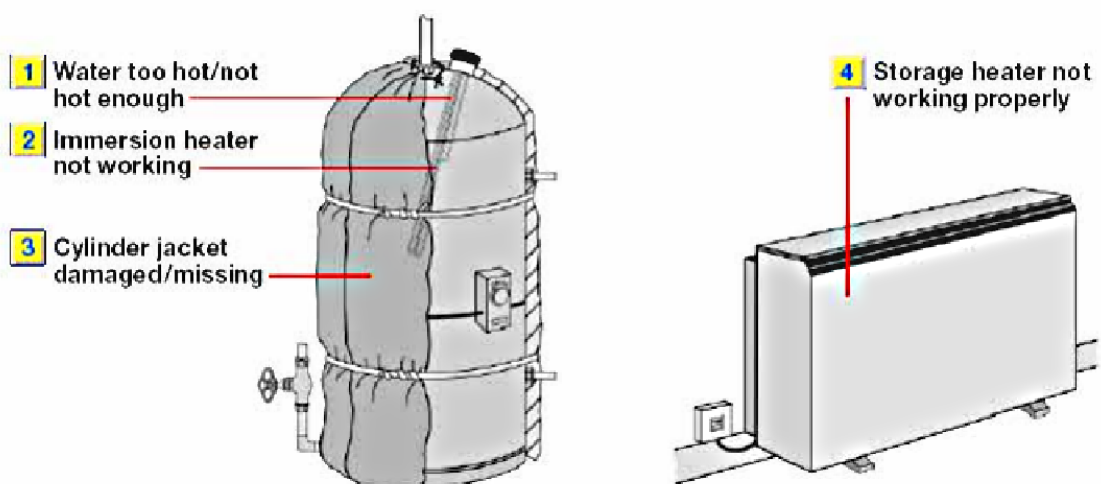

Kitchen units

What is the fault and its number?

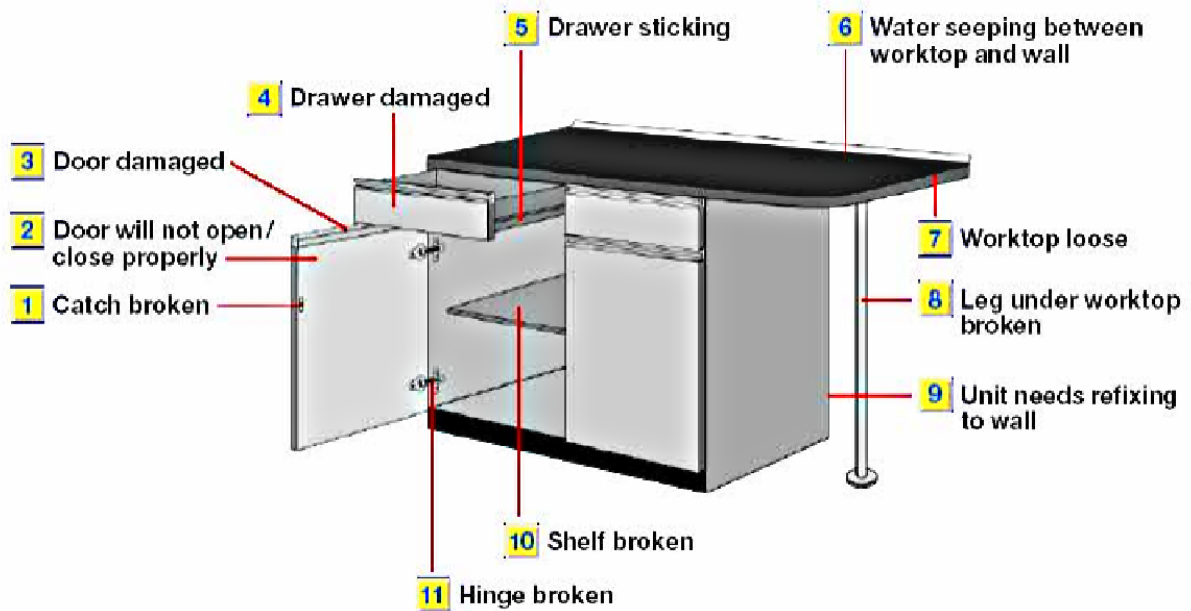

Roofs

What is the fault and its number?

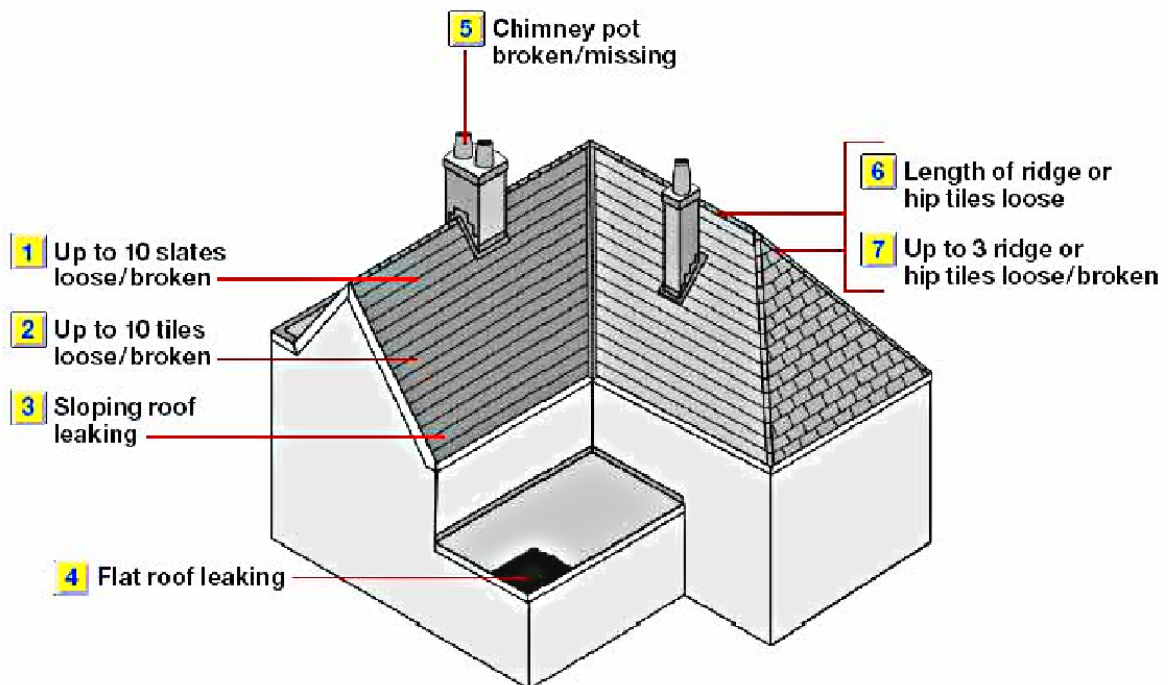

Sinks and basins

What is the fault and its number?

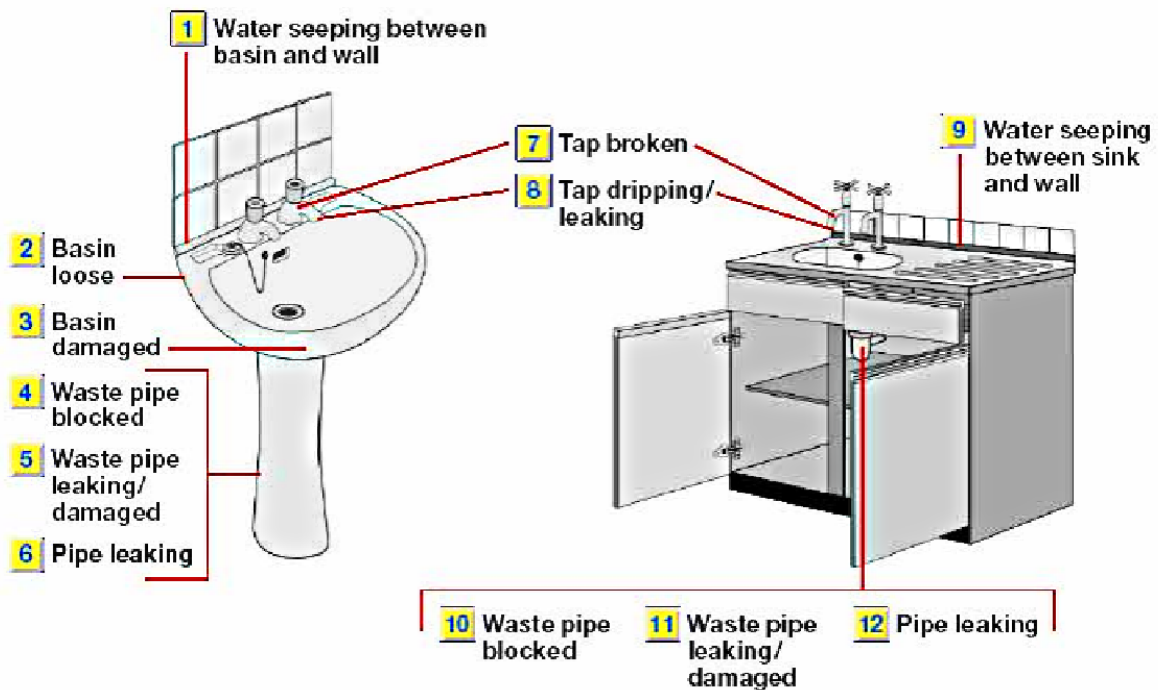

Stairs

What is the fault and its number?

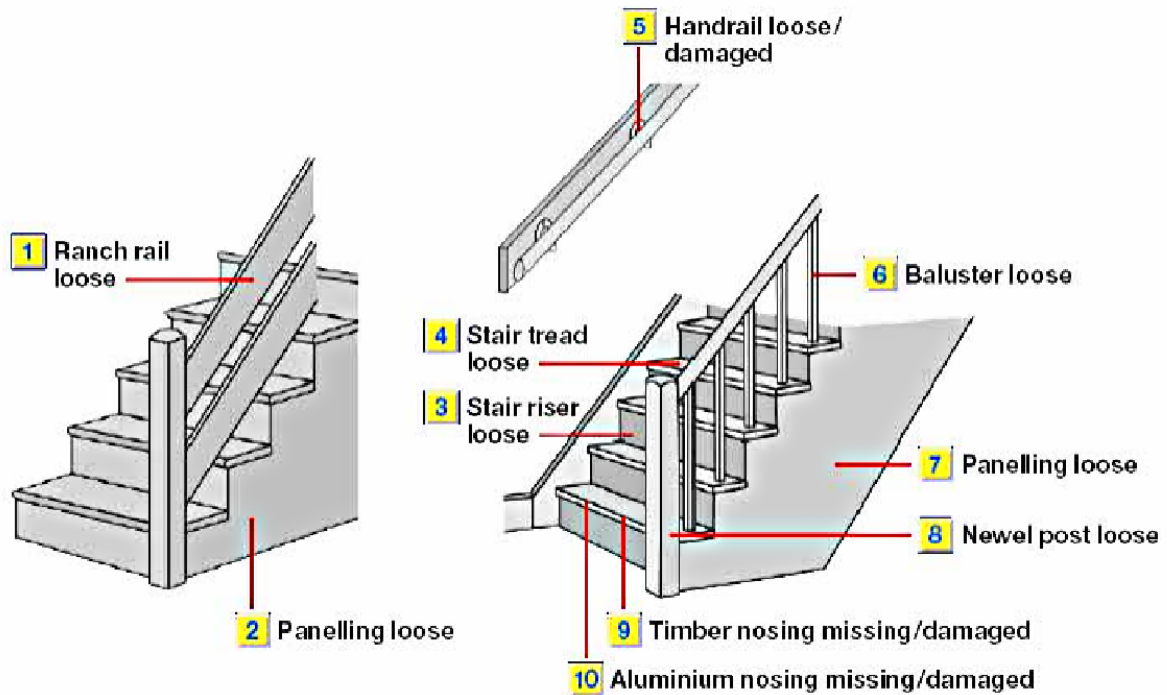

Toilets

What is the fault and its number?

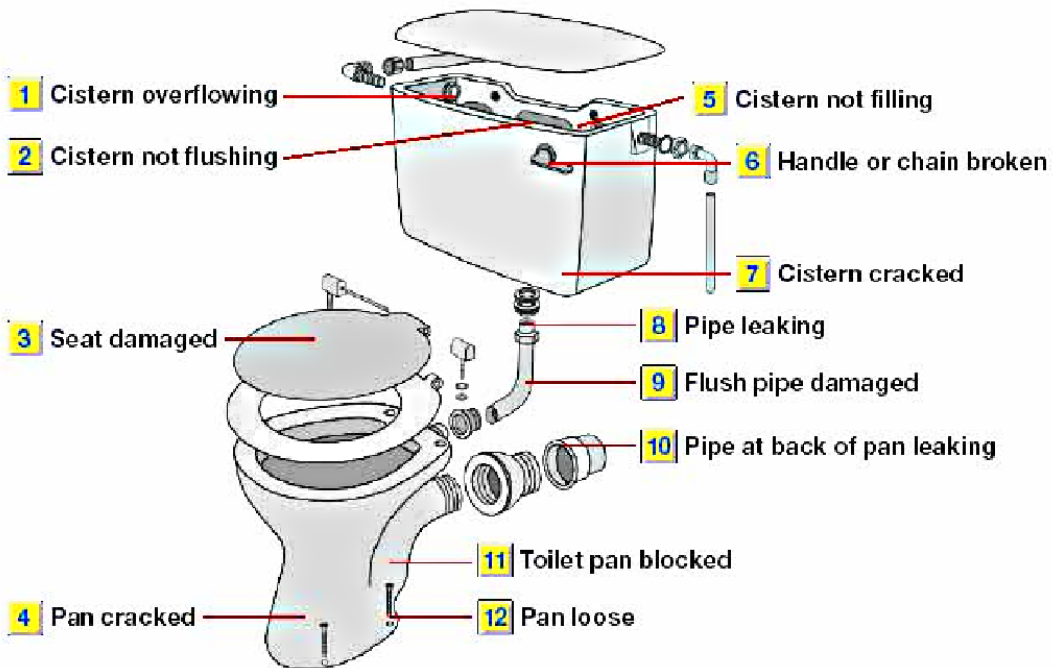

Water services

What is the fault and its number?

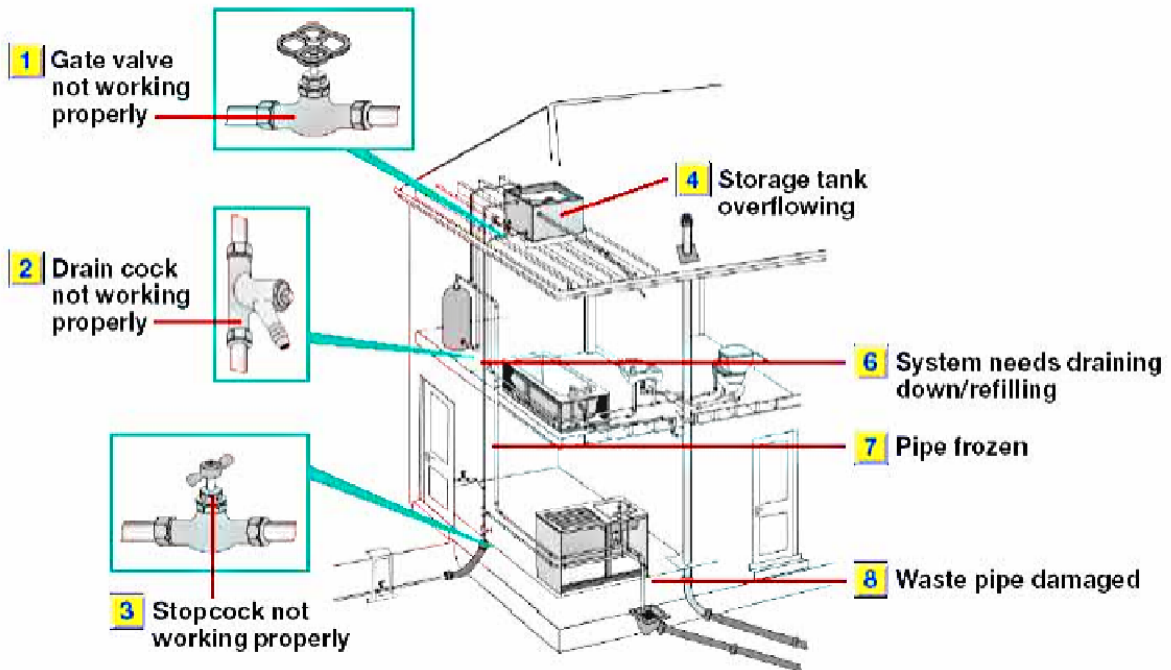

Windows - timber

What is the fault and its number?

Timber window

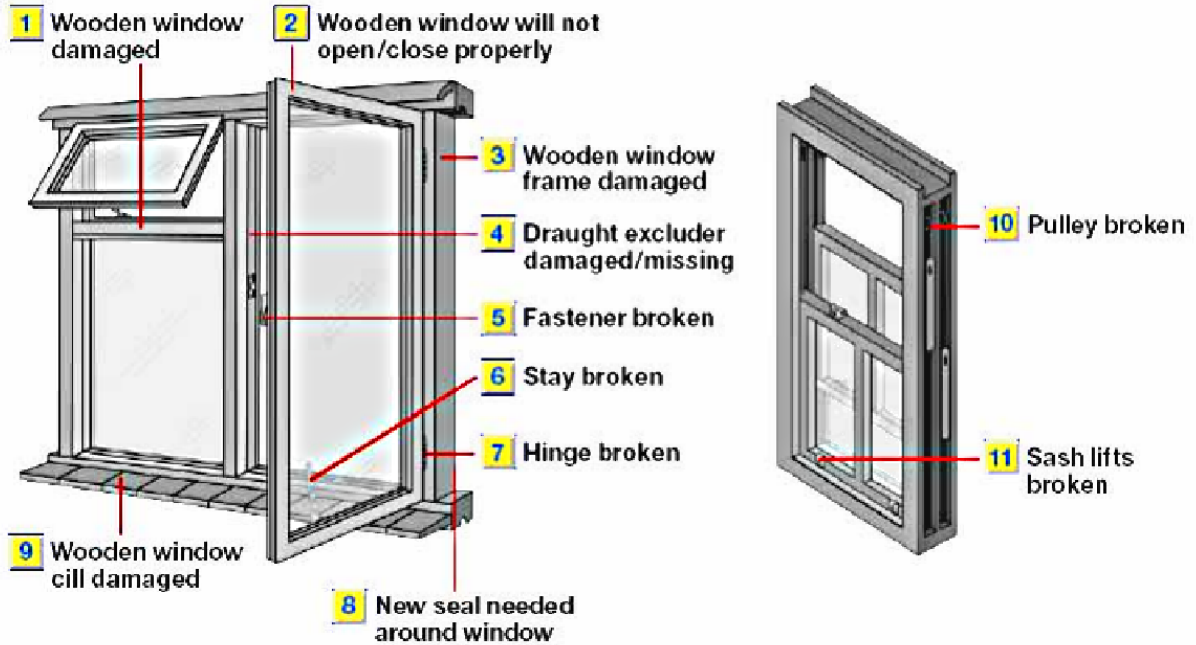

Windows - metal

What is the fault and its number?

Metal window

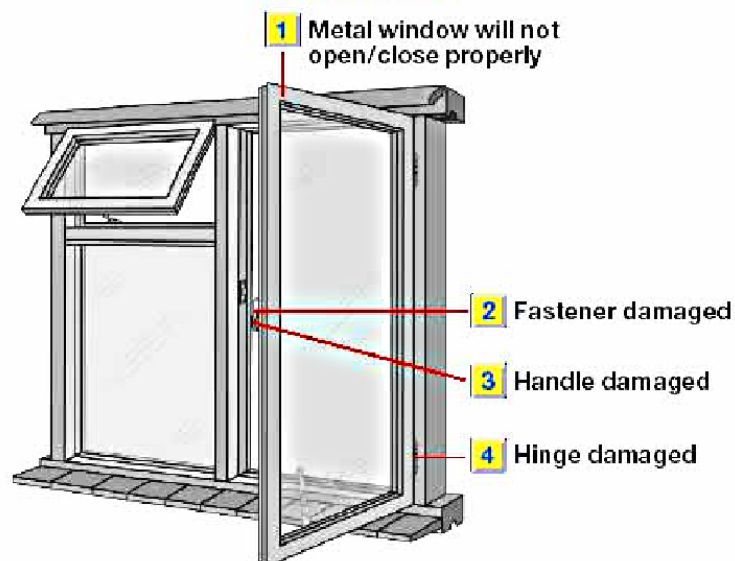

UPVc/Aluminium window

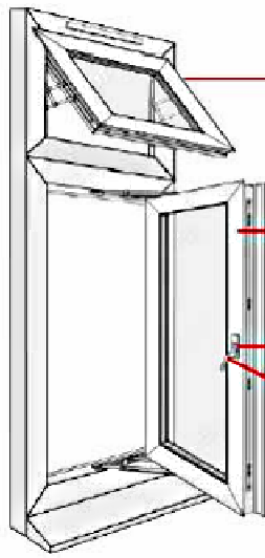

- 1 Water leaking around or through window
- 2 UPVc/aluminium window will not open/close properly
- 3 Fastener damaged
- 4 Handle damaged

- 5 Tilt and turn mechanism broken

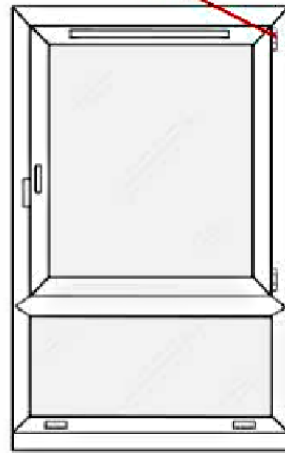

HideItHomes
A LOCAL EXPERT.